

VDSL2/ADSL2+ MULTIMODE RESIDENTIAL GATEWAY

FEATURES

- Highly integrated, single-chip VDSL2/ADSL2+ integrated access device (IAD) solution with seamless, multiuser support for 10/100/1000 Ethernet, USB 2.0 host and devices, ISDN, DECT™, multichannel VoIP, and IEEE 802.11a/b/g/n wireless home networking
- VDSL2/ADSL2+ auto-detecting, G.933.2 (G.vdsl2), G.992.1, G.992.2, G.992.3, G.992.5, and T1.413-compliant DSL transceiver
- Highly optimized concurrent multicore MIPS32® CPU with MMU, TLB support, and VoIP extensions
- Hardware ATM/PTM SAR, advanced ATM VC and PTM flow management, traffic shaping, channel bonding, and Quality of Service (QoS)
- Integrated hardware packet processing accelerator with support of wirespeed small packet bridging, routing, packet QoS, and IPSec
- Integrated Gigabit Ethernet switch core with four 10/100 Auto-MDIX Ethernet PHYs and two GMII/RGMII/MII interfaces
- Concurrent dual USB hosts and/or device interfaces with integrated transceiver
- Multiformat 16-/32-bit peripheral expansion bus
- Serial and parallel Flash interfaces with DDR support
- Extensive on-chip power management, EJTAG, GPIO, UART, NAND Flash interface, and OTP memory
- 35 mm x 35 mm package with 1.0 mm pitch for reduced PCB design complexity

SUMMARY OF BENEFITS

- High-performance VIPER™ CPU and special hardware accelerator support simultaneous small packet routing at wirespeed, multichannel VoIP, multiport Ethernet switching, IEEE 802.11b/g/n wireless networking, packet encryption/decryption, and advanced applications, such as remote management via TR-069.
- Integrated VoIP processing, using the widely deployed and field-hardened DSLxChange software, eliminates design complexity and cost.
- Embedded Gigabit Ethernet switch core with four 10/100 Auto-MDIX Ethernet PHYs and two GMII/RGMII/MII interfaces enhances system performance and reduces system cost.
- Concurrent dual USB host or device interfaces enable simple Plug and Play connection of multiple PCs, printers, storage, web cameras, and other peripheral devices.
- High-speed external expansion bus with support for CardBus and mini-PCI provides a seamless connection to onboard or module-based peripheral devices, such as IEEE 802.11a/b/g/n, MoCA™, HomePlug®, or HomePNA devices.
- Industry-standard multichannel TDM/PCM interface for glueless connectivity to SLAC and SLIC components for FXS/FXO support.
- Unified memory architecture supports all embedded applications including DSL, Routing, VoIP, Remote Management, Security, Ethernet, Bluetooth®, DECT, and Wi-Fi®.
- Support for industry-standard toolchains and operating systems including Linux®, Windows CE®, VxWorks®, and eCOS®.
- Consistent, field-hardened software platform across all Broadcom® CPE gateway devices.

BCM6368-based VDSL2/ADSL2+ Multimode Residential Gateway

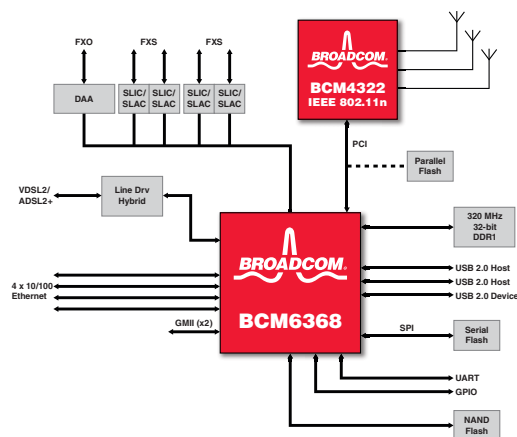

OVERVIEW

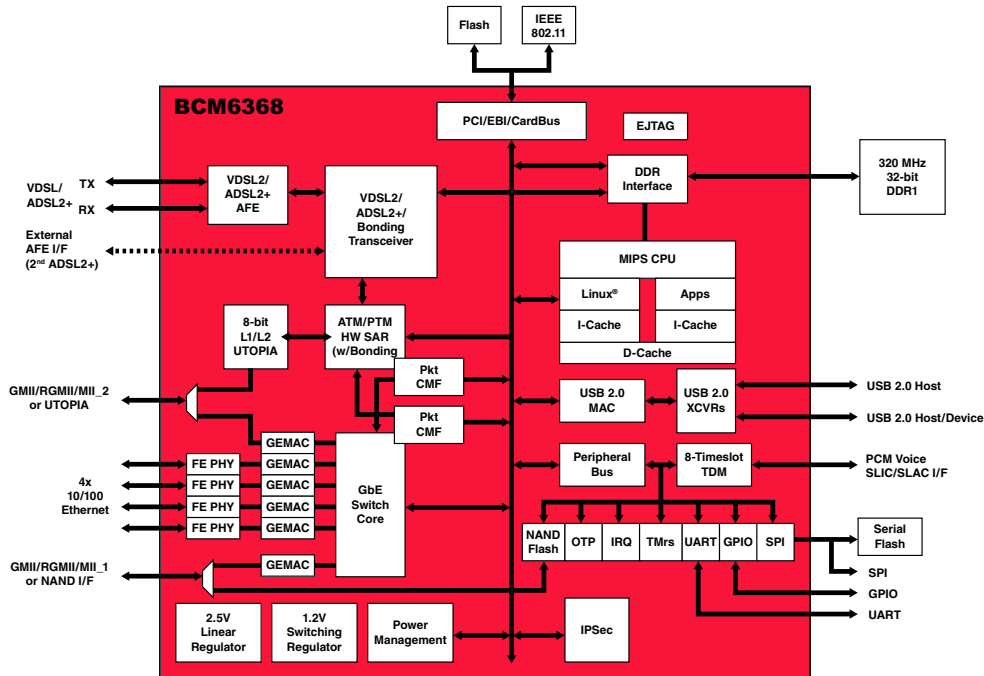

BCM6368 System Diagram

The BCM6368 combines a VDSL2/ADSL2+ transceiver and AFE with a high-performance multicore MIPS32 CPU, ATM/PTM hardware SAR, hardware packet-processing accelerator, Gigabit Ethernet switch core with four 10/100 Ethernet PHYs and dual GMII interfaces, dual USB Host/Device, multichannel TDM/PCM bus, parallel expansion bus supporting CardBus, and mini-PCI into a single high-performance monolithic device.

The VDSL2/ADSL2+ transceiver delivers 100 Mbps downstream and 50 Mbps upstream (100 Mbps upstream with external AFE), enhanced QoS for IPTV video, dual-latency framing, ATM or PTM physical layer, DSL channel bonding, and embedded operations channels for remote management of the CPE.

Powered by the advanced dual-core VIPER MIPS32 CPU and hardware packet processing accelerator, the BCM6368 VDSL2/ADSL2+ modem performs wirespeed bridging, routing, encryption, and decryption on all packet sizes between the WAN and the various LAN interfaces. The MIPS32 architecture-compliant VIPER CPU also supports custom application development with industry-standard EJTAG debuggers, toolchains, and development environments.

A full-featured ATM/PTM hardware SAR supports advanced QoS for multiple VCs in ATM mode and multiple flows in PTM mode. The embedded USB host/device and Gigabit Ethernet switch provide a wide range of connectivity options to PCs, printers, storage, video devices, Ethernet switches, and Bluetooth devices.

The expansion bus supports networking devices, such as Broadcom's IEEE 802.11a/b/g/n Wi-Fi chipsets, via CardBus and mini-PCI and generally available MoCA, HomePNA, and HomePlug devices as well as other video, storage, and security devices.

For voice applications, Broadcom's DSLxChange VoIP software provides a mature, field-hardened and reliable solution. A multichannel TDM/PCM interface is provided for connectivity to external SLAC and SLIC devices.

The BCM6368 enables the development of a completely integrated VDSL2/ADSL2+ IAD with advanced voice and application capabilities and unmatched functional integration.

For more information, contact your local Broadcom sales representative.

Broadcom®, the pulse logo, Connecting everything®, the Connecting everything logo, and VIPER™ are among the trademarks of Broadcom Corporation and/or its affiliates in the United States, certain other countries and/or the EU. Bluetooth® is a trademark of the Bluetooth SIG. Any other trademarks or trade names mentioned are the property of their respective owners.

Connecting
everything®



BROADCOM CORPORATION
5300 California Avenue
Irvine, California 92617

© 2008 by BROADCOM CORPORATION. All rights reserved.

6368-PB00-R 10/10/08

Phone: 949-926-5000
Fax: 949-926-5203
E-mail: info@broadcom.com
Web: www.broadcom.com